

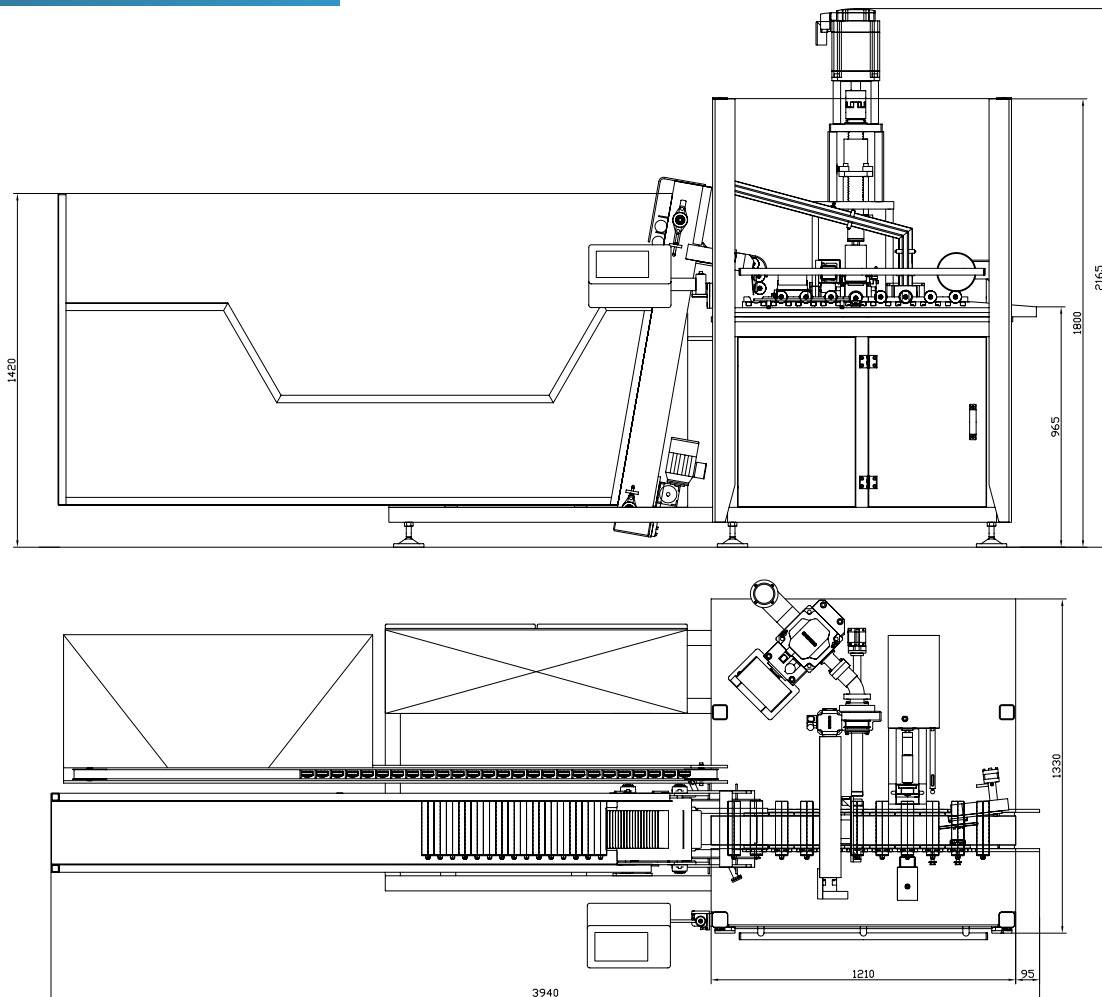

FILLING & CLOSING MACHINES

SERVO FILLER SV-1 ALU



From the Fischbach machinery line for cartridge filling, accessorizing and case packing.

Fischbach KG
51766 Engelskirchen, Germany
Telefon: +49 (0) 2263 6090
info@fischbach-fi.com

Fischbach Ibérica, S.A.
17410 Sils (Girona), Spain
Telefon: +34-972-16 84 87
spain@fischbach-fi.com

Fischbach Belgium N.V.
9140 Temse, Belgium
Telefon: +32-3-710 96 20
belgium@fischbach-fi.com

Fischbach USA Inc.
Elizabethtown, Kentucky, 42701 USA
Telefon: +1-270-7 69 93 33
usa@fischbach-fi.com

Fischbach Korea Co., Ltd.
Songpa-Gu, Seoul, Korea
Telefon: +82 2 425 3092
korea@fischbach-fi.com

Fischbach (Shanghai) Co., Ltd.
Shanghai, China 201708
Telefon: +86-21-6979-1423
china@fischbach-fi.com

Fischbach U.K. Ltd.
Cheshire WA7 1SN, Great Britain
Telefon: +44-1928-579320
uk@fischbach-fi.com

www.fischbach-fi.com



FILLING & CLOSING MACHINES

SERVO FILLER SV-1 ALU

Fischbach Servo Filler SV-1 ALU: Automatic filling, closing and marking of 60 aluminium cartridges per minute.

FEATURES

- > Precise, servo controlled volume dosing. Superior dosing accuracy at various viscosities.
- > Five axis SERVO operation allows adaptability to the widest variety of sealants and adhesives.
- > Superior process reliability at high operating speeds due to vacuum supported cartridge transport system.
- > Horizontal, closed loop fill sequence provides high speed air-free fill.
- > Cartridges fed from ground-level magazine holding 500 or 1000 standard cartridges.
- > Linear sensor controlled plunger insertion for 100% accurate positioning.
- > Quick release plunger station to aid in cleaning, maintenance and changeover.
- > Metering chain plunger sorter ensures consistent reliable performance for all plunger types.
- > Advanced, touch screen operator interface for fast and easy access to all machine functions.
- > One-piece sliding doors allow efficient cleaning and maintenance.

OPTIONS

- > Case Packer Fi-CH 100 and Palletizer Fi-PA, To create a fully automated, high performance line.

TECHNICAL DATA

Type: Single Head Cartridge Filling and Closing Machine SV-1 ALU

Output: 60 cartridges per minute at 310 ml

Dosing: Volumetric

Dosing Range: 240 ml to 500 ml

Connecting height at Product Infeed: 1000 mm or variable through optional height adjustment

Voltage: 3 x 400 V, 50 Hz or as requested

Control: Siemens Simotion D

Power: 16 KW/32 Amps

Air Pressure: 5 bar minimum (75 psi)

Air Consumption: 50 NL per minute

Weight: 1,500 kg



Fischbach KG
51766 Engelskirchen, Germany
Telefon: +49 (0) 2263 6090
info@fischbach-fi.com

Fischbach Ibérica, S.A.
17410 Sils (Girona), Spain
Telefon: +34-972-16 84 87
spain@fischbach-fi.com

Fischbach Belgium N.V.
9140 Temse, Belgium
Telefon: +32-3-710 96 20
belgium@fischbach-fi.com

Fischbach USA Inc.
 Elizabethtown, Kentucky, 42701 USA
Telefon: +1-270-7 69 93 33
usa@fischbach-fi.com

Fischbach Korea Co., Ltd.
Songpa-Gu, Seoul, Korea
Telefon: +82 2 425 3092
korea@fischbach-fi.com

Fischbach (Shanghai) Co., Ltd.
Shanghai, China 201708
Telefon: +86-21-6979-1423
china@fischbach-fi.com

Fischbach U.K. Ltd.
Cheshire WA7 1SN, Great Britain
Telefon: +44-1928-579320
uk@fischbach-fi.com

www.fischbach-fi.com