

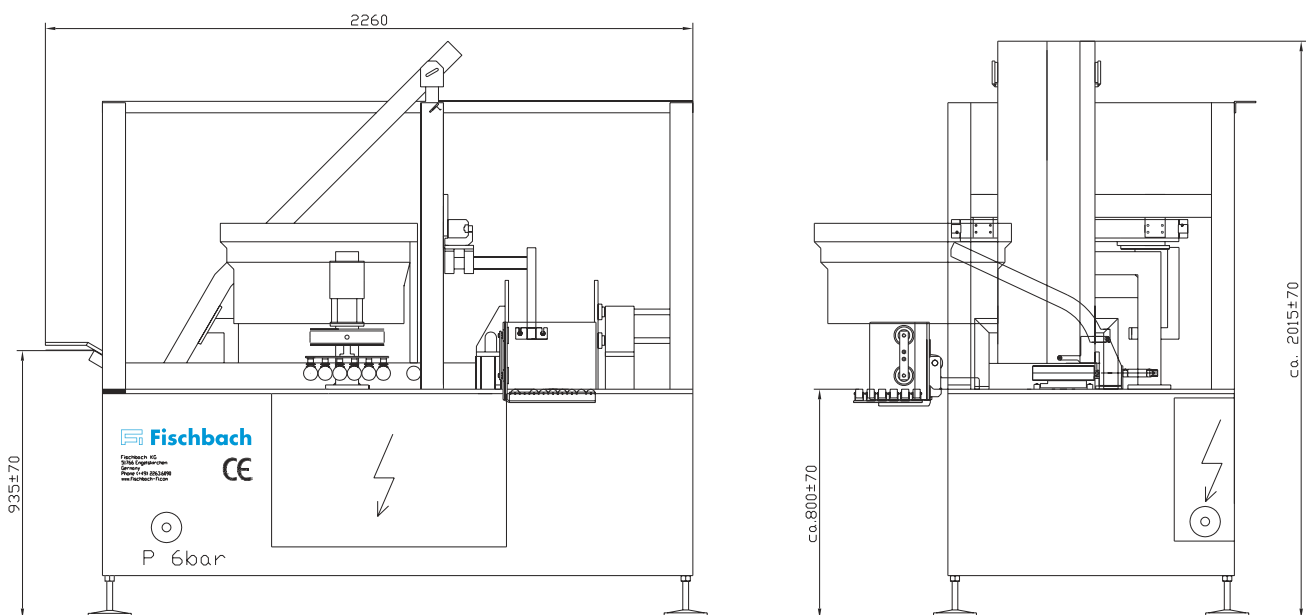

CASE PACKER

SEMI AUTOMATIC CARTRIDGE CASE PACKER FI-CL



From the Fischbach machinery line for cartridge filling, accessorizing and case packing.

Fischbach KG
51766 Engelskirchen, Germany
Telefon: +49 (0) 2263 6090
info@fischbach-fi.com

Fischbach Ibérica, S.A.
17410 Sils (Girona), Spain
Telefon: +34-972-16 84 87
spain@fischbach-fi.com

Fischbach Belgium N.V.
9140 Temse, Belgium
Telefon: +32-3-710 96 20
belgium@fischbach-fi.com

Fischbach USA Inc.
 Elizabethtown, Kentucky, 42701 USA
Telefon: +1-270-7 69 93 33
usa@fischbach-fi.com

Fischbach Korea Co., Ltd.
Songpa-Gu, Seoul, Korea
Telefon: +82 2 425 3092
korea@fischbach-fi.com

Fischbach (Shanghai) Co., Ltd.
Shanghai, China 201708
Telefon: +86-21-6979-1423
china@fischbach-fi.com

Fischbach U.K. Ltd.
Cheshire WA7 1SN, Great Britain
Telefon: +44-1928-579320
uk@fischbach-fi.com

www.fischbach-fi.com



CASE PACKER

SEMI AUTOMATIC CARTRIDGE CASE PACKER FI-CL

Fischbach Cartridge Case Packer Fi - CL: Up to 50 cartridges per minute accessorized and packed.

FEATURES

- > Packages all kinds of plastic, aluminium or cardboard cartridges in one or two -piece version
- > The compact modular design enables the machine to be optimally adapted to customers individual packaging requirements, while taking up a minimum of space
- > A packaging performance rate of 50 cartridges per minute with only one operator makes the Fi-CL the ideal supplement to any filling line
- > Cartridge accessorized with clip nozzles completely integrated in one automatic operating cycle
- > Program- controlled buffer magazine for 35 cartridges guarantees uninterrupted operation
- > Well designed system for easily adjusted case formats; change of format accomplished without tools within less than three minutes
- > Trouble-free operation due to latest process control and operation Interface.
- > Superior safety devices in compliance with European CE -Standard

TECHNICAL DATA

Output: Up to 50 cartridges per minute (depending on box format)

Types of Cartridges: All standard cartridges

Packaging formats: 2x4, 2x5, 2x6, 3x4, 3x5, 3x6, 4x4, 4x5, 4x6, 5x4, 5x5, and 5x6 cartridges per carton

Nozzle Accessorizing: Automatic clip nozzle station (rate: 50 nozzles per minute)

Sealing of carton: Externally - optional

Cartridge Buffer: Standard capacity 35 cartridges

Voltage: 3x 400 V, 50 Hz or as requested

Power Consumption: 300 W (800 W with clip nozzle station)

Fuses: 6 ampere

Control Voltage: 24 V (internal)

Process Control: Siemens PLC

Air Pressure: 6 bar minimum (90 psi.)

Air Consumption: 120 NL per minute (210 NL with clip nozzle station)

Weight: 600 kg



Fischbach KG
51766 Engelskirchen, Germany
Telefon: +49 (0) 2263 6090
info@fischbach-fi.com

Fischbach Ibérica, S.A.
17410 Sils (Girona), Spain
Telefon: +34-972-16 84 87
spain@fischbach-fi.com

Fischbach Belgium N.V.
9140 Temse, Belgium
Telefon: +32-3-710 96 20
belgium@fischbach-fi.com

Fischbach USA Inc.
 Elizabethtown, Kentucky, 42701 USA
Telefon: +1-270-7 69 93 33
usa@fischbach-fi.com

Fischbach Korea Co., Ltd.
Songpa-Gu, Seoul, Korea
Telefon: +82 2 425 3092
korea@fischbach-fi.com

Fischbach (Shanghai) Co., Ltd.
Shanghai, China 201708
Telefon: +86-21-6979-1423
china@fischbach-fi.com

Fischbach U.K. Ltd.
Cheshire WA7 1SN, Great Britain
Telefon: +44-1928-579320
uk@fischbach-fi.com

www.fischbach-fi.com